

ARCORA®
GERMANY

SD17



Please read carefully the instruction manual and safety instructions before using.

Failure to observe the instruction-manual and safety instructions may cause damage or danger to the operator and other persons.

The machine with its durable planetary gear-box is perfect for demanding usage.

The standard water tank and the toolless disk change make work trouble-free.

The complete accessory package enables hard surfaces to be cleaned or polished as well as for carpets to be shampooed.

SAFETY



WARNING!
Risk of injury!

- ⚠ This apparatus is not to be used by people (children included) with reduced physical, sensorial or mental capacities or without any experience and knowledge, unless they did not receive instructions relative to the use of the apparatus and are controlled by a person responsible for their safety.
- ⚠ Children should be controlled so that they didn't play with the apparatus.
- ⚠ The packaging components could constitute potential dangers (as for example plastic bags): they must be kept away from children's reach and from other people not conscious of their actions.
- ⚠ Any different use from that indicated in this manual could constitute a danger, therefore, it must be avoided.
- ⚠ Every part of the apparatus must be correctly assembled before using it.
- ⚠ Ensure that the socket conforms to the apparatus' plug.
- ⚠ Ensure that the voltage indicated on the motor block corresponds with the power that is intended to connect the apparatus to.
- ⚠ Avoid positioning the suction aperture next to delicate parts of the body such as eyes, mouth, ears, etc., while the apparatus is functioning.
- ⚠ Make sure that the machine is switched off before plugging the power cord in.
- ⚠ The apparatus is not suitable for areas protected against electrostatic discharges.
- ⚠ Use only the brushes supplied with the apparatus or those specified in the instruction manual. Using other brushes could jeopardize safety.
- ⚠ When operating the rotating parts, (e.g. brush, disc wheel, etc.) a danger exists when running over the power supply line or extension cords, or even coming into contact with them. The cable could be damaged with substantial risk caused to the machine and to the user.
- ⚠ Don't leave the apparatus unattended while it is in function.



WARNING!
Danger of electric shock!

- ⚠ Do not ever pull or lift the apparatus through the electrical cable.
- ⚠ Do not immerge the apparatus into water and neither use water ets to clean it.
- ⚠ Always remove the plug from the current socket before undertaking any type of intervention on the apparatus or if it is left unattended or within children or people's reach not quite conscious of their own actions.
- ⚠ Regularly control the feeding cable looking for damages, cracks or ageing. Substitute the cable before using it further.
- ⚠ If the feeding cable is damaged it must be substituted by the manufacturer or by its after sales service or in any case by a similarly qualified person, thus preventing any possible risk.
- ⚠ When using extension electric wires ensure that they are lying on dry surfaces and protected against possible water jets.



WARNING!
Risk of injury!

- ⚠ Specialized personnel must always carry out maintenance and repairs; any damaged part must be substituted with original spare parts.
- ⚠ It is forbidden to carry out changes to the apparatus. Tampering could cause fires and damages even lethal to the user and the forfeiture of the guarantee.
- ⚠ The manufacturer declines any responsibility for damages caused to people or things due to non-compliance with these instructions or if the apparatus is unreasonably used.



Do not dispose of power tools into household waste! According to the European Directive 2002/96 EC on waste electrical and electronic equipment (WEEE) and its incorporation into national law, power tools that are no longer suitable for use must be separately collected and sent for recovery in an environmental-friendly manner.

Old appliances contain valuable materials that can be recycled. Please arrange for the proper recycling of old appliances. Batteries, oil, and similar substances must not enter the environment. Please dispose of your old appliances using appropriate collection systems.

UK
CE Declaration of conformity



We declare under our sole responsibility according to EG 2006/42/EG, that this product is in conformity with the following standards or standardization documents.

Product: Single disc machine
Type: SINGLE DISC

Applied harmonized standards
CE-LVD+EMF+CEEMC
EN60335-1: 2002
EN60335-2-10: 2003

ARCORA INTERNATIONAL GmbH, 85609
Aschheim / Germany
08/2018

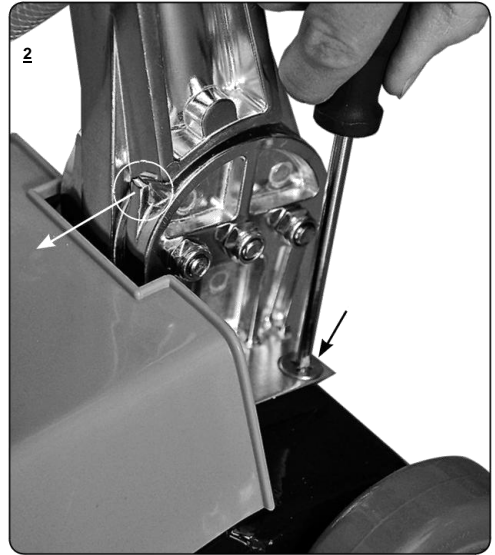
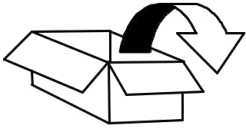

Sami Memili
Managing Director

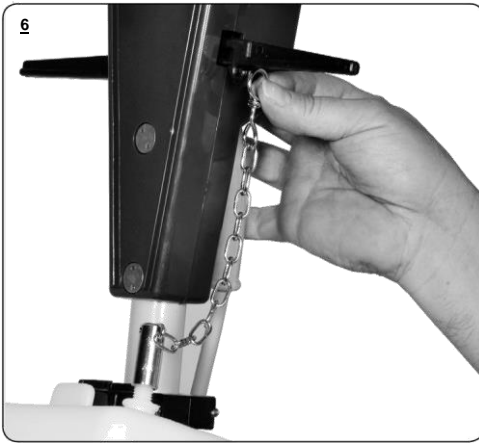

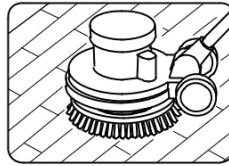

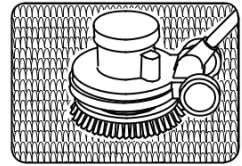

Hartfläche / hard
floor grün / green



empfindliche
Böden sensitive
floors blau / blue

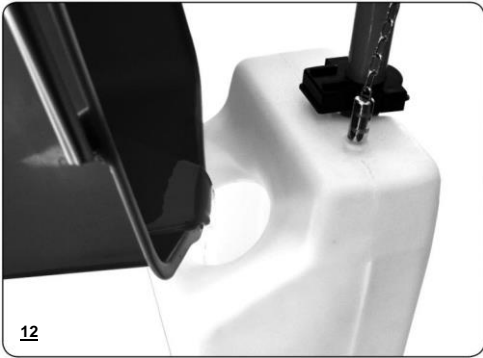

12



14

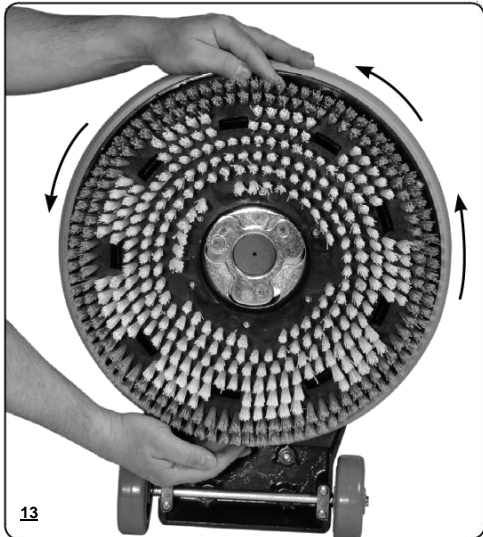

13

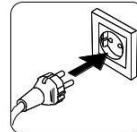

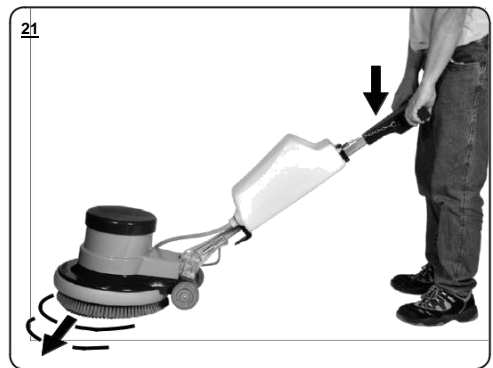
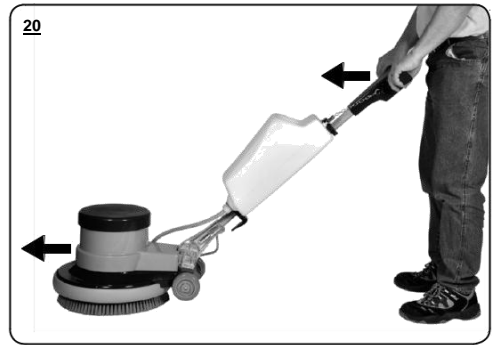
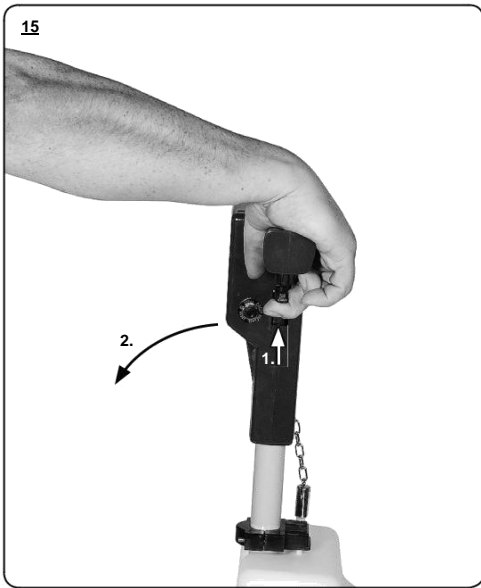

22

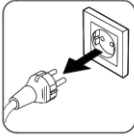
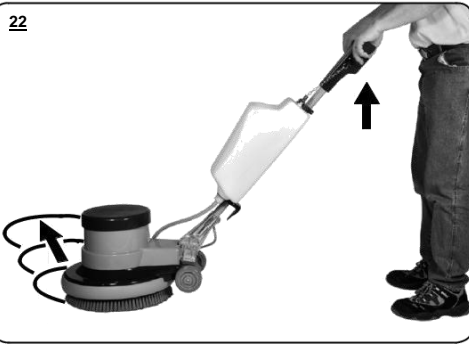

23



24

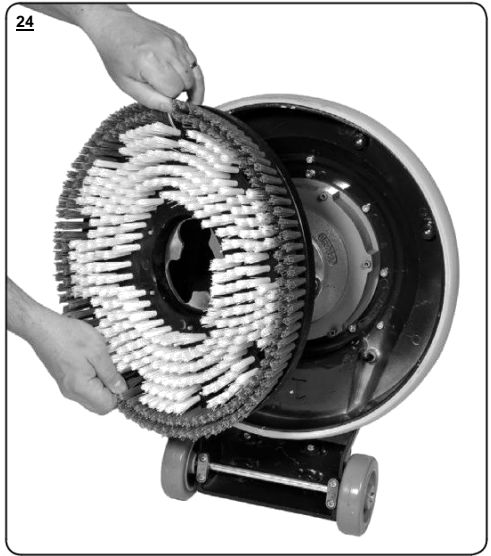

25



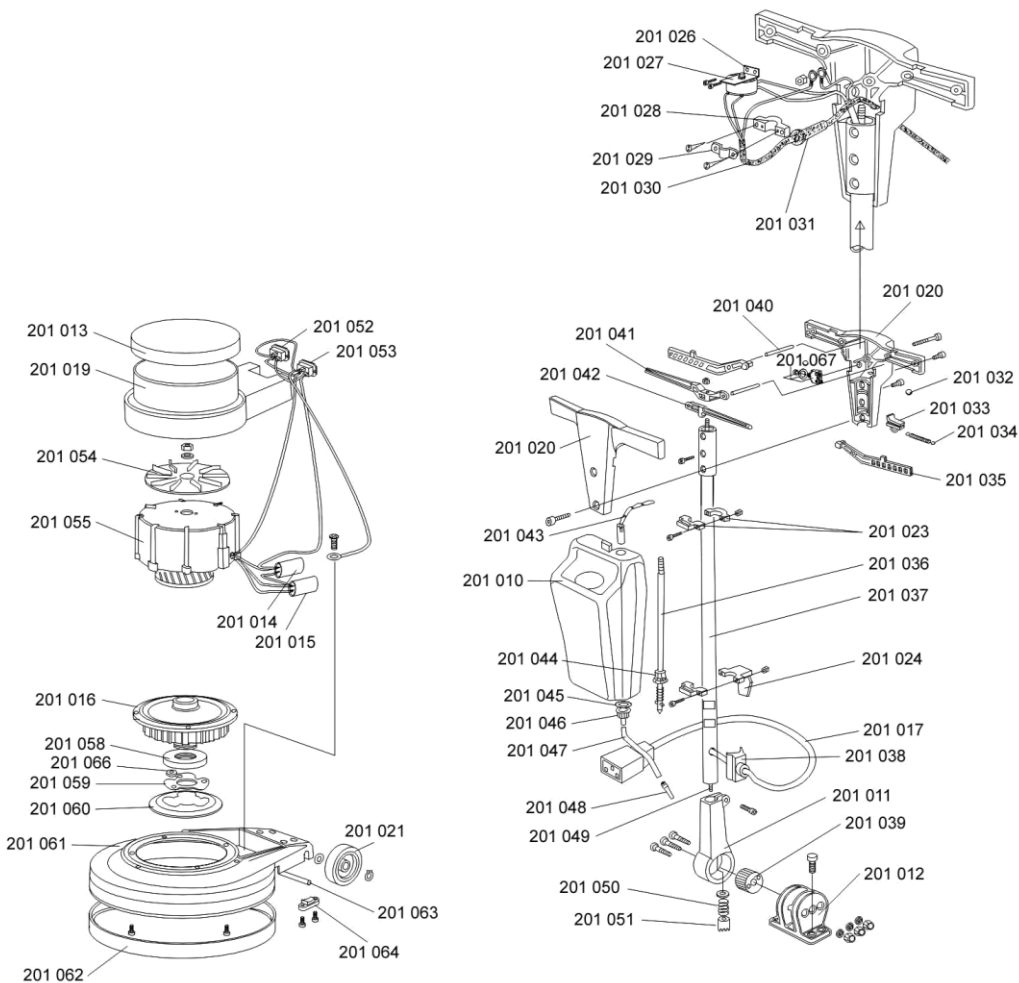

Standardzubehör / Standard Accessories

Bürste weich /
Brush soft
blau / blue

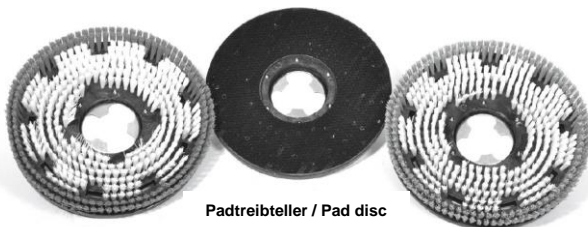

Bürste hart /
Brush hard floor
grün / green

Padtreibsteller / Pad disc

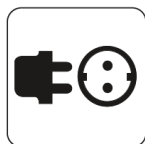

220-240 V /
50 Hz

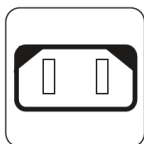

1200 W



38 kg



420 x 550
x 1210 mm



154 U/min

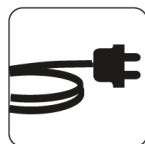

12 m



Ø 17 /
432 mm

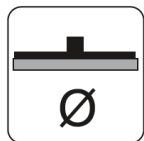

Ø Pad max.
17" / 432 mm



10 Liter

We reserve the right to effect modifications within the framework of technical progress!

ARCORA INTERNATIONAL GmbH
Marsstraße 9 - 85609 Aschheim by Munich - Germany
phone: +49 (0)89 14 33 29 3-0 - fax: +49 (0)89 14 33 29 3-29
mail: info@arcora.de - web: www.arcora-group.com

**PRIME
CLEANING
SUPPLIERS**



COMPLETE CLEANING SOLUTIONS®

www.primecs.co.za

WESTERN CAPE - 021 551 4570

GAUTENG - 086 111 6008

GARDEN ROUTE - 044 878 1356

EASTERN CAPE | SM SALES - 041 365 2886

MBOMBELA | SM SALES - 013 010 1247

KZN | PAPER LOGIC HYGIENE - 032 944 7750

FREE STATE | IDFS - 051 448 1230

CLEANING CHEMICALS/ DISINFECTANTS ▼ PAPER PRODUCTS/DISPENSERS ▼ CLEANING SUNDRIES

All product names, ® Registered Trademarks are property of their respective owners © 2024 - All Rights Reserved